

**Article for the Proceedings of the
International Symposium on Radiometric Dating Studies, Nagoya University**

**Development of an Automated Combustion and Gas-fed Ion Source System
for Environmental Monitoring and Biomedical ^{14}C Applications**

W. E. Kieser, K. Leung, N. Krestina, R. P. Beukens, X-L Zhao and A. E. Litherland

Environmental monitoring in the event of an accidental or malicious release of ^{14}C -laden material would require the analysis of a large number of samples, at levels between 1 and 10^4 times modern. A similar level of ^{14}C concentration is present in samples resulting from the use of ^{14}C for tracing in bio-medical applications, particularly for following the pathways of metabolites in the development of pharmaceuticals. These applications also generate large numbers of samples and both areas of application would benefit from reduced sample preparation time and labour. The recent commercial availability of gas-fed ion sources permits the development of systems which eliminate the graphitization process and, for high levels of ^{14}C , increase the analytical throughput.

A system which includes an automated combustion unit to produce carbon dioxide, a gas transfer and storage system and the direct generation of carbon anions from the CO_2 is being developed at IsoTrace. This system was primarily funded for environmental monitoring purposes by the Canadian CBRN Research and Technology Initiative program, but will be kept in a state of readiness through its use for biomedical analysis. With the substitution of alternate transfer lines, it is expected that this system will also be quite useful for the measurements of ^{14}C concentrations in the range of 0 to 15 ka BP. A plan view of the equipment is shown in figure 1.

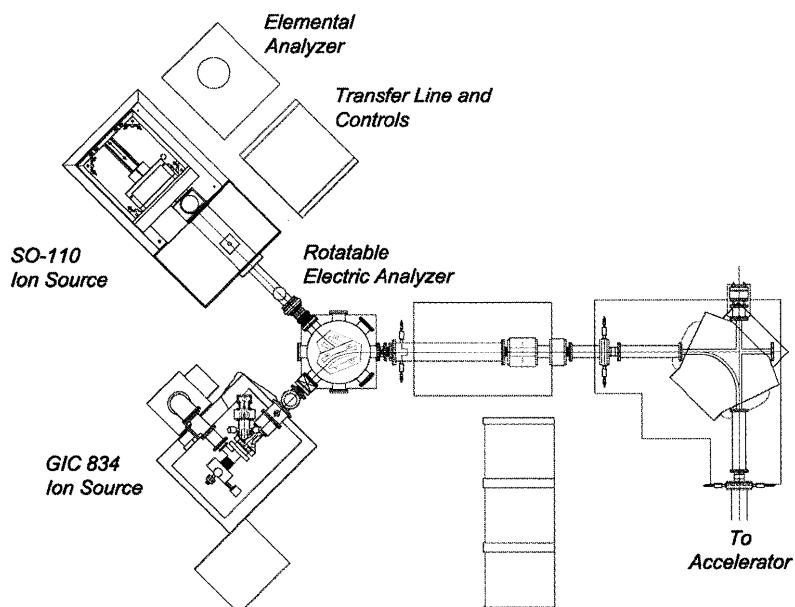

Figure 1: Plan view of the injection line of the IsoTrace AMS system. The electrodes of the electric analyser can be rotated so that ion beams from either the older GIC834 ion source or the new SO-110 source can be selected for injection into the accelerator.

The ion source is a High Voltage Engineering model SO-110 hybrid gas / solid source, which has been installed on the IsoTrace AMS injection line at the -45° port of the rotatable electric analyser. The combustion unit is an Elementar Vario ELIII CNS elemental analyser which provides separate trapping and release for the analyte gases. A gas dilution, storage and transfer line has been built locally to connect these two units. A schematic diagram, illustrating the internal functions of these units, is shown in Figure 2.

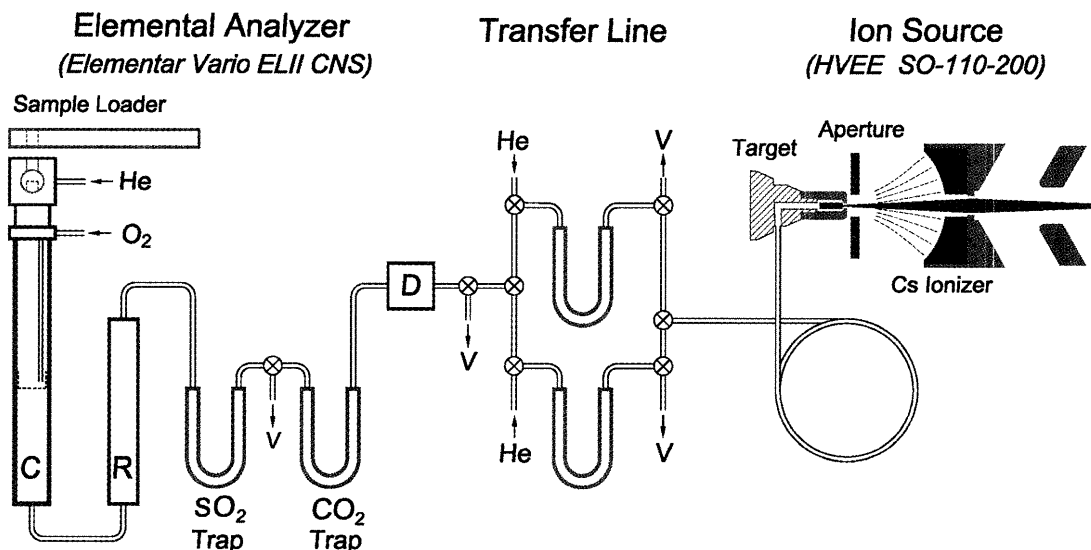

Figure 2: Schematic showing the functions of the three components of the automated system. Item C is the combustion tube, R is the reduction tube, D is a thermal conductivity detector and those labelled V are vents. Water traps are not shown, to simplify the illustration.

The principal tasks of the gas transfer line are to accommodate the discharge of CO₂ in the He carrier stream from the elemental analyser and to prepare it for injection into the ion source. At a constant flow rate of 200 ml per minute, the CO₂ is released as a peak in concentration over a duration ranging from 1 to 3 minutes as shown in Figure 3. The ion source requires a steady flow of a uniform concentration of CO₂ in He at a rate of $\sim 200 \mu\text{l}$ per minute. The transfer system includes a mixing unit which injects additional He into the CO₂ / He mixture from the elemental analyser to produce a stream with relatively constant CO₂ concentration.

The amount of He injected is determined by a mass flow controller which follows the profile of the CO₂ peak measured by the thermal conductivity detector (TCD) in the elemental analyser. The resulting gas stream is then fed into a heated stainless steel loop and finally injected into the ion source. A

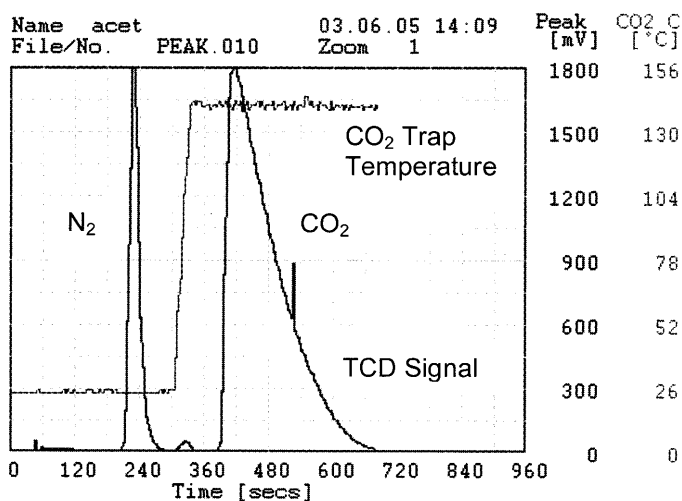

Figure 3: Display from the elemental analyser control screen showing the signal from the thermal conductivity detector and temperature of the CO₂ trap. The latter adsorbs the CO₂ at room temperature and releases it at $\sim 140^\circ\text{C}$

schematic of the transfer line is shown in figure 4. An advanced version of this line will consist of two sample loops, so that the elemental analyser can be processing the next sample while the first one is being analysed on the AMS system.

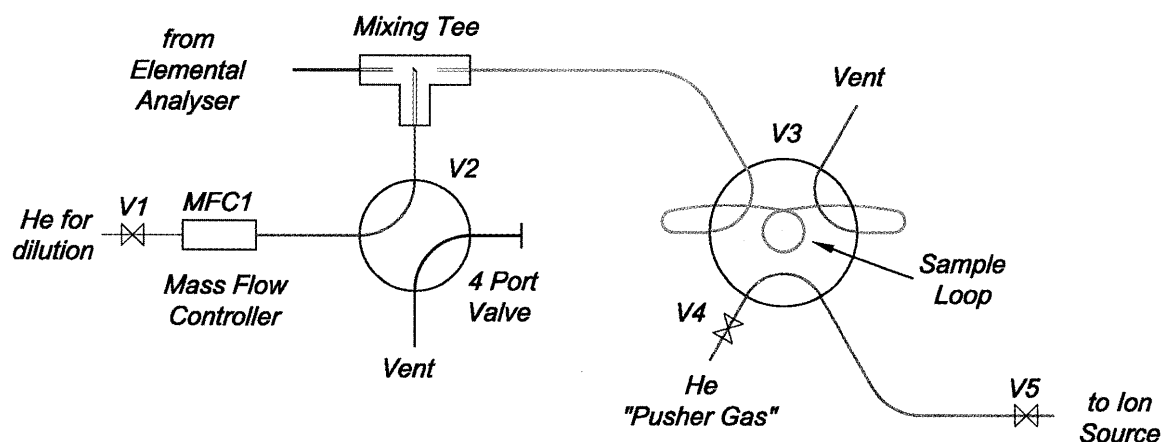

Figure 4: Schematic of the CO₂ transfer and dilution line. Valve V2 allows the mass flow controller MFC1 to be adjusted and then switched into the mixing tee when the CO₂ pulse from the elemental analyser passes through the tee. When the CO₂ / He mixture arrives at the end of the sample loop, valve V3 switches the loop to feed the source.

For the analysis of gas samples, the SO-110 uses a target containing a titanium pellet over which the CO₂ gas is flowed while being bombarded by the caesium sputtering beam, as shown in Figure 5. As the Ti pellet is sputtered, a small (~0.5 mm diameter) crater is formed and the C⁻ ion current tends to increase. The C⁻ current can be optimized by adjusting parameters such as the feed rate of CO₂ into the source, the intensity of the Cs beam and the position of the Ti pellet within the target. At the high currents of Cs required for gas mode operation, the original design of the Cs feed to the ionizer (from one side) produced a Cs spot on the target approximately 0.5 mm off centre (Figure 6). We have just installed a re-designed Cs feed system in which the Cs enters from six holes symmetrically spaced around the axis of the ionizer. This has significantly improved the centring of the Cs spot on solid targets as well as the stability and intensity of the C⁻ current produced as shown in Figure 7.

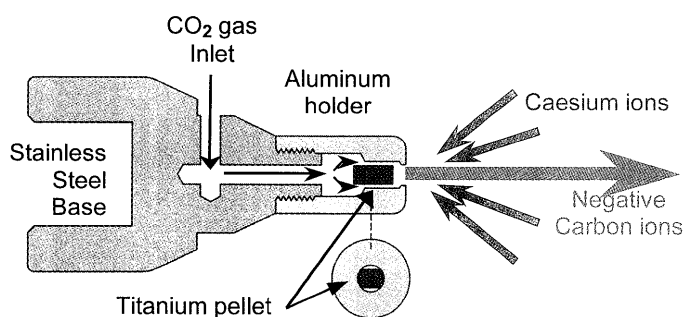

Figure 5: Cross section of target piece used to create the environment for producing C⁻ ion beams from CO₂ gas

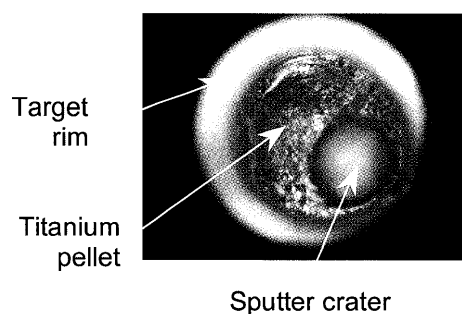

Figure 6: Microphotograph of sputtered target showing off-axis crater.

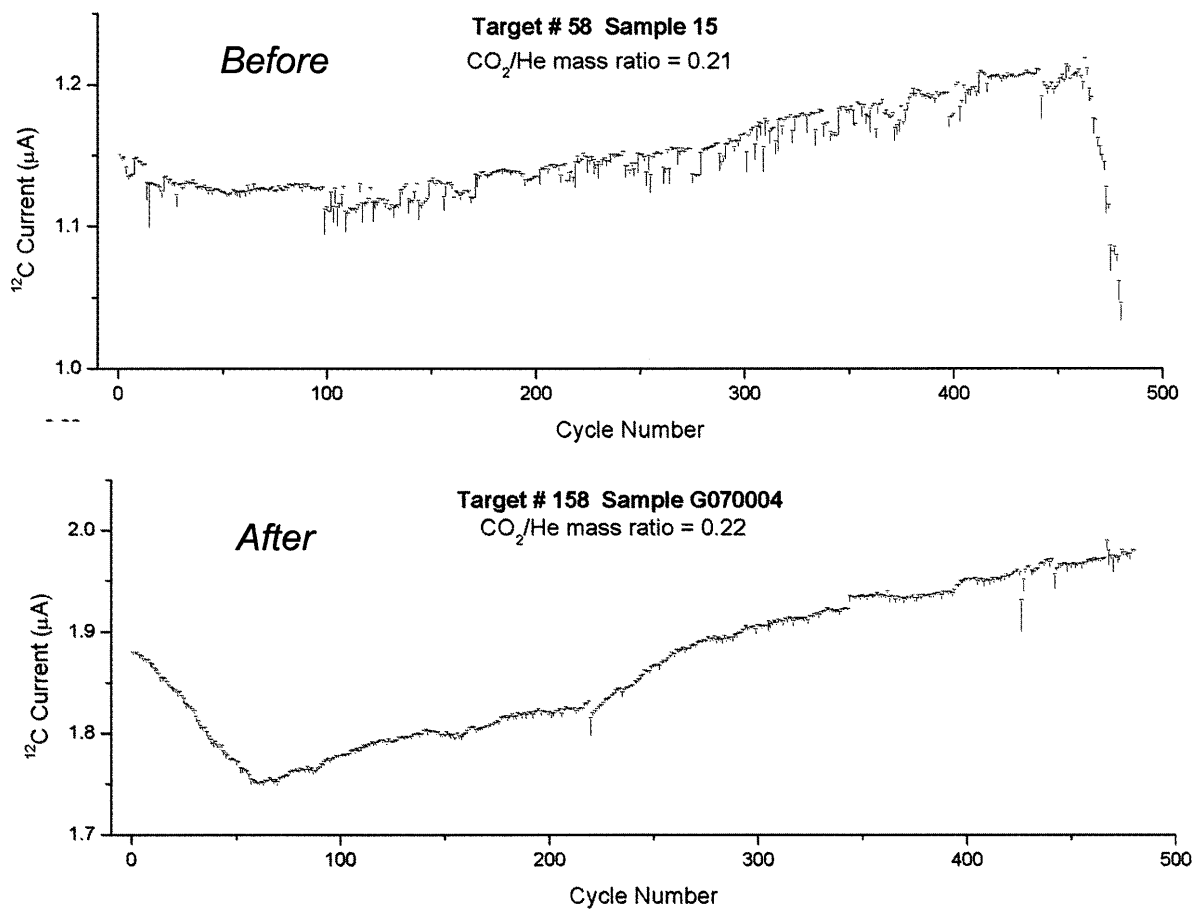

Figure 5: $^{12}\text{C}^{3+}$ current measured in the post accelerator Faraday cup, analysed before and after the installation of the annular caesium vapour feed, with other source conditions remaining the same. Improvements in both the stability and intensity of the current can be seen.

In order to operate the gas transfer line and to synchronize with it the operation of the elemental analyzer and the ion source, a system using a programmed logic controller (PLC) is being implemented. On a command from the AMS system computer, the PLC initiates the combustion of the next sample, reads the thermal conductivity detector signal and operates the mass flow controller on the He dilution feed to provide a constant CO₂ to He ratio, inserts a clean target into the SO-110 and switches the storage loop valve to feed the sample into the source. A schematic of this system is given in Figure 8.

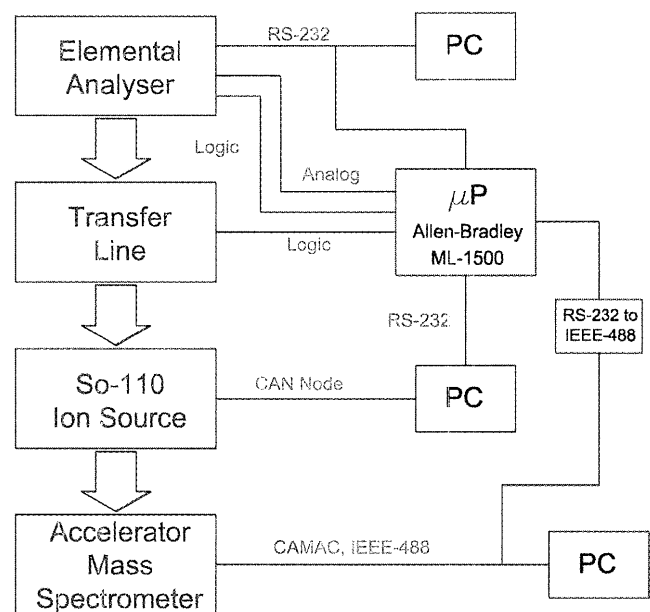

Figure 6: Schematic showing the components and communications links of the PLC based control system.

For environmental monitoring of ^{14}C under emergency conditions, samples such as vegetation, soil, air filters or surface swipes will be collected. These are easy to obtain and require little processing before combustion in the elemental analyser. Organic liquids can be combusted, but liquids containing large quantities of water would require lyophilisation so that the water traps on the elemental analyzer are not overloaded. As these samples may have significantly higher ^{14}C concentration than those normally analysed, separate laboratory will be required for reception, cataloging and encapsulation of this material

For bio-medical samples, more time can be allocated to sample preparation, so a wider variety of samples can be analysed. Typical bio-medical applications include the use of ^{14}C labelled compounds for tracing metabolic pathways taken by particular components of these compounds through complex systems. A comprehensive review of AMS biomedical applications and techniques is provided by Vogel [1]. AMS not only permits the use of much lower levels of ^{14}C labelling (typically 10s to 100s of nCi rather than 100s of μCi for conventional testing), it can alternatively facilitate tests with reduced quantities of the compound that must be administered.

This latter advantage is beginning to be exploited by pharmaceutical companies in the development of new drugs. If the amount of a drug to be administered is 100 times lower than the level considered toxic, regulatory agencies will permit tests to be carried out directly on human subjects to determine the rates of absorption or elimination from the body, before extensive animal testing takes place. This technique, known as microdosing, can significantly reduce the cost and time required for the development of new drugs. The large scale animal testing required often does not adequately predict the availability, kinetics or dynamics of the compounds in the human system. Microdosing allows such factors to be assessed before the animal testing and human clinical trial stages, thus eliminating these expensive tests for compounds which are found to be unsuitable.

Reference:

1. J. S. Vogel, *Accelerator mass spectrometry for human biochemistry: The practice and the potential*, Nuclear Instruments and Methods **B172** (2000) pp. 884-891